

REED

Model R5007

True RMS Digital
Multimeter
Instruction
Manual



[www reedinstruments com](http://www.reedinstruments.com)

Table of Contents

Safety	3
Features.....	3
Specifications.....	3-5
Instrument Description	6
Operating Instructions.....	7-11
<i>AC/DC Voltage Measurements</i>	<i>7</i>
<i>Resistance Measurements</i>	<i>7</i>
<i>Circuit On/Off Measurement</i>	<i>8</i>
<i>Diode Measurements.....</i>	<i>8</i>
<i>Capacitance Measurements</i>	<i>8</i>
<i>Frequency/Duty Ratio Measurements</i>	<i>9</i>
<i>Temperature Measurements</i>	<i>9</i>
<i>AC/DC Current Measurements</i>	<i>9</i>
<i>Current Clamp Measurements</i>	<i>10</i>
<i>Non-Contact AC Voltage Sensing</i>	<i>10</i>
<i>Max/Min Display</i>	<i>10</i>
<i>Relative Measurements</i>	<i>10</i>
<i>Display Hold.....</i>	<i>10</i>
<i>Auto Power Off</i>	<i>11</i>
Battery Replacement.....	11

Safety

- Designed in compliance with the following: IEC/EN61010-1, Pollution Grade II, Overvoltage CATIII600V and Double Insulation
- Take caution when measuring Voltages above 60DC or 30AC RMS

Features

- Measures AC/DC Voltage, AC/DC Current, Variable Frequency Voltage (VFC), Resistance, Capacitance, Frequency Ratio, Non-Contact AC Voltage Sensing (NCV), Clamp Meter measurements (with optional clamp meter) and Temperature
- Auto and Manual Range
- Auto Power Off and Backlight
- Max/Min, Relative Mode, and Data Hold

Specifications

LCD Display:	6000 Count, 58 × 36 mm
Bandwidth:	45 to 1kHz
Duty Cycle:	0.1 to 99.9%
Diode:	Around 3V
Battery Test:	1.5V / 9V
Auto Power Off:	Around 15 Minutes
Input Protection:	600V RMS
Input Impedance for DCV:	1GΩ Max
Power Supply:	2 x AA 1.5V Batteries
Weight:	370g
Dimensions:	175 x 80 x 48.5 mm
Includes:	Test Leads and Type K Temperature Probe
Optional Accessories:	Magnetic Hanger with Strap (R5900)

Measurement Specifications

Function	Range	Resolution	Accuracy
DC Voltage	60.00mV	10 μ V	$\pm(0.5\% \text{ rdg} + 2 \text{ dgts})$
	600.0mV	0.1mV	
	6.000V	1mV	$\pm(0.7\% \text{ rdg} + 3 \text{ dgts})$
	60.00V	10mV	
	600.0V	0.1V	
	600V	1V	
AC Voltage	60.00mV	10 μ V	$\pm(1.0\% \text{ rdg} + 3 \text{ dgts})$
	600.0mV	0.1mV	
	6.000V	1mV	$\pm(0.8\% \text{ rdg} + 3 \text{ dgts})$
	60.00V	10mV	
	600.0V	0.1V	
	600V	1V	$\pm(1.0\% \text{ rdg} + 3 \text{ dgts})$
DC Current	600.0 μ A	0.1 μ A	$\pm(0.7\% \text{ rdg} + 2 \text{ dgts})$
	6000 μ A	1 μ A	
	60.00mA	10 μ A	
	600.0mA	0.1mA	$\pm(1.0\% \text{ rdg} + 3 \text{ dgts})$
	6.000A	1mA	
	10.00A	10mA	
AC Current	600 μ A	0.1 μ A	$\pm(1.0 \text{ rgd} + 3 \text{ dgts})$
	6000 μ A	1 μ A	
	60.00mA	10 μ A	
	600.0mA	0.1mA	$\pm(1.2\% \text{ rdg} + 3 \text{ dgts})$
	6.000A	1mA	
	10.00A	10mA	

Measurement Specifications Cont.

Function	Range	Resolution	Accuracy
Resistance	600.0Ω	0.1Ω	±(1.0% rdg + 2 dgts)
	6.000KΩ	1Ω	±(0.8% rdg + 2 dgts)
	60.00KΩ	10Ω	
	600.0KΩ	100Ω	
	6.000MΩ	1kΩ	±(1.2% rdg + 3 dgts)
	60.00MΩ	10KΩ	±(1.5% rdg + 5 dgts)
Capacitance	9.999nF	1pF	Under REL (±4%+10)
	99.99nF to 999.9μF	10pF to 0.1μF	±(4% rdg + 5 dgts)
	9.999mF to 99.99mF	1μF to 10μF	±10% rdg (≤2mF)
VFC	200.0V to 600V	0.1/1V	±(4.0% rdg + 3 dgts)
Battery Capacity	1.500V	1mV	±5%
	9.00V	10mV	
Frequency	9.999Hz to 9.999MHz	0.001Hz to 0.001MHz	±(0.1% rdg + 4 dgts)
	1 to 99.9%	0.10%	Not defined
Temperature	-40 to 0°C	1°C	±3
	>0 to 100°C		±(1.0% rdg + 3 dgts)
	>100 to 1000°C		±(2.0% rdg + 3 dgts)
	-40 to 32°F	1°F	±5
	>32 to 212°F		±(1.5% rdg + 5 dgts)
	>212 to 1832°F		±(2.5% rdg + 5dgts)

Instrument Description

1. LCD Screen
2. REL Button
3. HZ/% Button
4. SELECT/VFC Button
5. VΩHz Input
6. COM Input
7. mAμA Input
8. A Input
9. Function Switch
10. HOLD/LIGHT Button
11. RANGE Button
12. MAX/MIN Button

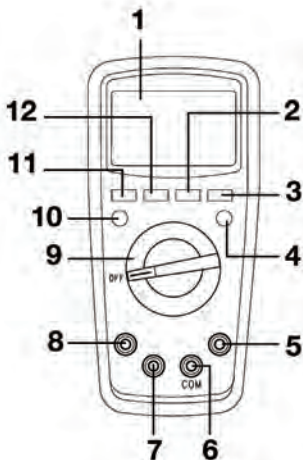

Display Description

1. Relative Icon
2. Units of Measurement
3. Low Battery Icon
4. Auto-Power Off Icon
5. 6000 Count Display
6. Current Clamp Icon
7. MAX/MIN Icon
8. Auto-Range Icon
9. Non-Contact Voltage Icon
10. Data Hold Icon
11. Circuit On/Off Icon
12. Diode Icon
13. Negative Reading
14. AC/DC Icon



Operating Instructions

AC/DC Voltage Measurements

1. Set the Function Switch to the V or mV position.
2. Insert the Red test lead to the V Ω Hz% Input and the Black test lead in the COM Input.
3. Press the RANGE Button to select the range manually. Start from a higher range if you are not sure about the flow under test.
4. Connect the test leads to the power under test. Read the results on the LCD.

Resistance Measurements

1. Set the Function Switch to the Ω position.
2. Insert the Red test lead to the V Ω Hz% Input and the Black test Lead in the COM Input.
3. Press the RANGE Button to select the range manually. Start from a higher range if you are not sure about the flow under test.
4. Completely discharge all capacitors before taking a measurement.
5. Connect the test leads to the load under test. Read the results on the LCD. Measurements $\geq 10\mu\text{F}$ will take several seconds to stabilize. To avoid damage or injury do not apply voltages above 60 DC or 30 AC RMS.
6. To check the built-in fuse, see the image below.

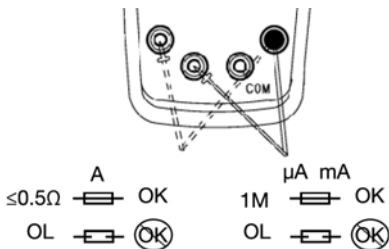

Circuit On/Off Measurement

1. Set the Function Switch to the Ω position.
2. Insert the Red test lead to the V Ω Hz% Input and the Black test lead in the COM Input.
3. Turn the circuit power off and discharge all residual charges to ensure accuracy.
4. Connect the test leads to the two terminals under test. The meter will beep if the resistance is $\leq 10\Omega$. If the resistance is $\geq 150\Omega$ the meter will not beep.

Diode Measurements

1. Set the Function Switch to the Ω position.
2. Insert the Red test lead to the V Ω Hz% Input and the Black test lead in the COM Input.
3. Turn the circuit power off and discharge all residual charges to ensure accuracy.
4. Connect the test leads to the circuit under test. "OL" will appear on the LCD if the diode is an open circuit or if polarity is reversed.

Capacitance Measurements

1. Set the Function Switch to the Ω position.
2. Insert the Red test lead to the V Ω Hz% Input and the Black test lead in the COM Input. The LCD will display a measurement, which is the internal fixed capacitance value. When measuring small range gear capacitance, that value needs to be subtracted from the measured value to ensure accuracy. The REL function can be used to automatically subtract the value.
3. Connect the test leads to the circuit under test. Measurements $\geq 10\mu\text{F}$ will take several seconds to stabilize. To avoid damage or injury do not apply voltages above 60 DC or 30 AC RMS.

Frequency/Duty Ratio Measurements

1. Set the Function Switch to the HZ position. Press the Hz/% button for Frequency measurements.
2. Insert the Red test lead to the V Ω Hz% Input and the Black test lead in the COM Input.
3. Connect the test leads to the load under test. Read the results on the LCD. To avoid damage or injury do not apply voltages above 60 DC or 30 AC RMS.

Temperature Measurements

1. Set the Function Switch to the °C position.
2. Insert the Red wire into the V Ω Hz% Input and the Black wire into the COM Input.
3. Touch the probe to the item under test. Read the results on the LCD. Temperature Measurements can only be taken by a Type K Thermocouple Probe. Do not exceed temperatures of 230°C/446°F.

AC/DC Current Measurements

1. Set the Function Switch to the μ A, mA, or A position.
2. Insert the Red test lead to the mA μ A Input and the Black test lead to the COM Input. Cut off the current before connecting the meter to the loop.
3. Press the RANGE button select the range. Start from a higher range if you are not sure about the current flow under test.
4. Connect the test leads to the load under test. Read the results on the LCD. Press the HZ/% button to display the AC online frequency/duty ratio.

Current Clamp Measurements

Note, the Optional Clamp Meter is required to make Current Clamp Measurements.

1. Set the Function Switch to the 60A position.
2. Insert the Red wire into from the Clamp Meter into the VΩHz% Input and the Black wire into the COM Input.
3. Press the jaw trigger on the Clamp Meter and place it around one wire to be measured. Read the results on the LCD.

Non-Contact AC Voltage Sensing

1. Set the Function Switch to the NCV position.
2. Place the front end of the meter near the object to be sensed.
3. Critical voltage will be displayed as “-”. Varied buzzing sounds and line marks on the LCD will appear in accordance with the level of sensed Voltage.

Max/Min Display

While taking a measurement, press the MAX/MIN button to display the Maximum measured value. Press the button again to display the Minimum measured value. Press the button a third time to resume normal measuring.

Relative Measurements

While taking a measurement, press the REL button to use the displayed value as a reference point. The displayed measured value will be the difference between what is being measured and the reference point. Press the button again to resume normal measuring.

Display Hold

Press the HOLD Button to freeze the displayed value. Press the button again to resume normal measuring.

Auto Power Off

This meter will automatically turn off after 15 minutes of inactivity. One minute before turning off the meter will beep. The meter will beep again when it goes into Auto Power Off mode. Press any button to turn the unit back on. Press and hold the SELECT button to turn the feature off. The feature will turn back on the next time it is powered on.

Battery Replacement

1. Turn the function switch to the OFF position, remove any test leads, and remove the protective case from the meter.
2. Unscrew the rear cover and remove from the meter. Replace the dead batteries with new ones. Be sure to fully reassemble the meter before turning it on.

For service (repairs or calibration) on this or any other REED product or information on other REED products, contact REED Instruments at info@reedinstruments.com

Notes

Notes _____
